

## Polymer-Carbon Composite Supporting Structure

Damian Markuszewski<sup>1\*</sup>, Michał Bielak<sup>1</sup>, Mariusz Wądołowski<sup>1</sup>, Aleksandra Grzybek<sup>1</sup>

<sup>1</sup> Faculty of Automotive and Construction Machinery Engineering, Warsaw University of Technology, ul. Narbutta 84, 02-524 Warsaw, Poland

\* Corresponding author's e-mail: [damian.markuszewski@pw.edu.pl](mailto:damian.markuszewski@pw.edu.pl)

### ABSTRACT

The combination of polymeric materials used in 3D printing and carbon fibers gives designers new possibilities in the design of light load-bearing structures. Such a reinforced material can be found in thin-walled structures. A good example is the wheel of a Mars rover, the structure of which is expected to be low in weight, with adequate strength and durability as well as deformations within the assumed range - ensuring vibration damping in the rigid suspension of a special vehicle. The paper presents the process of designing such a wheel within the limits of the European Rover Challenge competition regulations and the technological possibilities of a low-budget project. The conducted experiment confirmed the correctness of the assumptions and indicated potential directions for further work.

**Keywords:** carbon fiber; strength of materials; polymer materials; Martian rover.

### INTRODUCTION

Technical progress will soon allow mankind to colonize the Moon and Mars. In this way, we will solve many problems, for example with a shortage of energy and natural resources. Physical exploration of outer space is currently preceded by flights of unmanned probes and space vehicles collecting data and collecting samples. Space flights are very expensive and their implementation requires huge investment. A threat to this type of mission is the lack of direct human intervention and a long control delay resulting from the long distance. The priority is therefore the detailed planning of the mission, taking into account the smallest details and potential weaknesses of the mission. The use of autonomy as much as possible becomes crucial, due to the delay in the transmission of radio waves.

The progenitor and the most mentioned vehicle in the history of spaceflight is the Lunar Roving Vehicle (LRV). The vehicle used in the Apollo 15 mission is the first Polish accent in this field. The co-creator of the vehicle was the scientist and

engineer Prof. Mieczysław Bekker, a graduate of the Warsaw University of Technology.

Observing the development of Mars rovers, it is not difficult to notice the increase in the weight and size of vehicles and the increasing number of tasks to be performed. Examples include the Perseverance rover and the small Ingenuity drone that provides valuable photos.

The modern rover is a mobile research platform with a robotic arm, adapted to move over difficult terrain. Its task is to facilitate the work of astronauts and help in the exploration of difficult and unknown areas. Such a vehicle moves at low speed for short distances. While driving, you may encounter many obstacles, including bumps, rocks and chasms. Moving on such terrain requires great stability, which can be obtained by lowering the center of gravity with an enlarged track and axle. Assumptions made by construction are often contradictory. The constructors have to deal with the gravitational field of Mars, which is three times smaller than on Earth, and at the same time the overloads affecting the vehicle during the rocket launch, which translates into later durability. The next challenge is the center

on which the rover moves. Extremely fine sand can immobilize the rover, as in the case of Spirit [16]. Tires should have a sufficiently large surface, which increases the rolling resistance and increases electricity consumption. Dust storms limiting the effectiveness of photovoltaic panels are a big problem. In the latest solutions, a radio-isotope thermoelectric generator has been used as the main power source. In order to extend the service life of the vehicle, it is necessary to use actuators that ensure low electricity consumption. The next threat are high-energy particles from space, dangerous to electrical systems.

The use of composite materials in such a vehicle may allow for a better optimization of shape and weight, which will improve the functionality of the vehicle, and the resulting lightweight laminate structure is less sensitive to the magnetic field.

Technologies, and often finished products developed for the needs of space missions, are very often also used on Earth. Thanks to modern computers and artificial intelligence, sending more and more efficient robots will continue – and this is probably the only real perspective of exploring the cosmos for now.

## RIM DESIGN

For stability reasons, a proven solution was chosen – a six-wheel rocker-bogie suspension (Fig. 1). The “double tripod” is more stable than the suspension of a four-wheeled all-terrain vehicle. The applied suspension evenly distributes the



Fig. 1. Mars rover prototype [20, 21]

pressure of the wheels on the ground and reduces the frequency of frame vibrations by swaying the frame in relation to the two support points. In this way, the delicate electronics of the vehicle are better protected.

This study deals with the Martian rover’s drive system, namely the wheel. The design should be characterized by: low weight, assumed strength. It should also take into account unforeseen dynamic loads that may occur during operation and dampen vibrations. The prototype, which is to take part in the ERC competition, assumed the weight of the vehicle 60 kg, which, with an

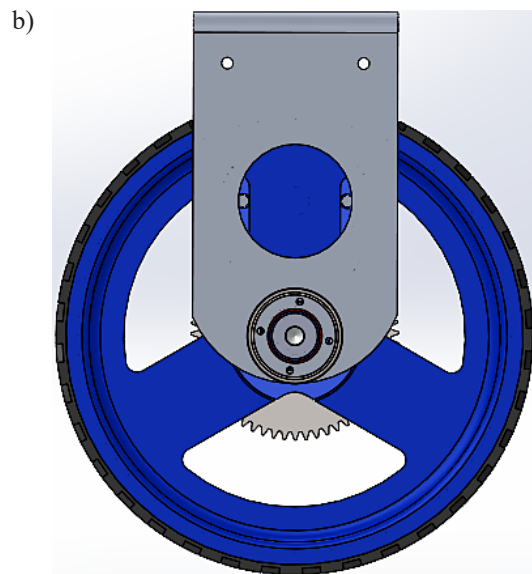
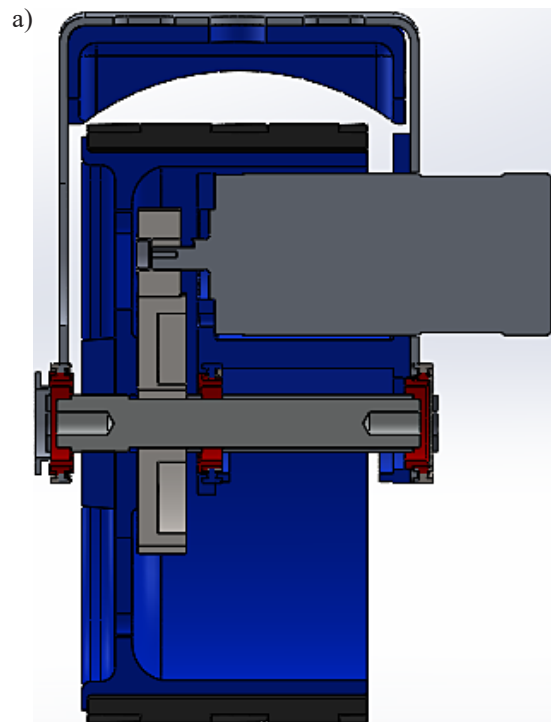

Fig. 2. Mars rover crossover project

even weight distribution over 6 wheels and a safety factor of 2.5, gives a load of 246 N. The use of 3D printing allows for a very flexible approach to shaping the product. In this case, the rims are built compactly with the drive system in the steering knuckle. The rim design was made as part of a low-budget student project - a Mars rover competing in the European Rover Challenge competition. Due to the innovative idea and the relatively easy availability of technology, the members of the Bekker Team Science Club chose PLA thermoplastic material with a filament diameter of 1.75 mm, dimension tolerance  $\pm 0.05$ , print temperature from 190 °C to 230 °C and temperature for the rim material. Bed temperature from 0 °C to 60 °C, not requiring a closed working chamber. The available 3D printer had a working area limiting the outer dimension of the rim to  $\varnothing 210$  mm.

The variant of the 3-arm support of the rim was chosen due to the installation of the steering knuckle, the last stage gear wheel is mounted on the pin of the drive motor through a suitably shaped hole in the rim and steering knuckle.

The second gear of the last stage is mounted on the inside of the rim on a shoulder. Due to the weight reduction, the drive motor is supported by a basket (Fig. 3) made in the same technology as the rim - i.e. PLA.

A 24V BLDC motor with an encoder using a Hall sensor was chosen for the drive. The 60W three-phase 4-pole motor used is connected to two 1:10 factory gears ( $z_1 = 8$ ,  $z_3 = 72$ ) on the first stage and 1:3 ( $z_1 = 35$ ,  $z_3 = 72$ ) on the second stage. In order to ensure the speed of the vehicle in accordance with the guidelines of the European Rover Challenge competition, i.e. 0.5 m/s [15] and work in the appropriate range due to energy consumption, one external step with a

deceleration ratio of 1:3 ( $z_1 = 20$ ,  $z_2 = 59$  material C35) was added.

The rim with the drive system is supported in three nodes on an aluminum drive shaft with a key. Left bearing fixed in the housing and on the shaft, two more fixed only on the shaft – they move longitudinally in the holders. Bearings type 6803 2RS were used. The durability of the drive system is limited by the manufacturer's use of an engine in a planetary gear with plastic planetary gears up to 5000h. The entire drive system is mounted in a switch made of a suitably shaped aluminum sheet with a thickness of 3.5 mm. In order to improve the stiffness of the system, there is an element also made of PLA in the upper part of the crossover. Spacers in the form of sleeves are made of aluminum or PLA.

Work began with printing a 200 gram rim and making a special 200 gram carbon fiber reinforcement band with a single weave of 200 g/m<sup>2</sup> gradation. The headband consists of three layers of fabric 0/45/90 oriented carbon fiber. The layers were made in the technology of manual lamination in a mold with a filling ratio of Epidian 5 with Z1 hardener resin and 40/60 reinforcement. The airless tire is maintenance-free and follows the tradition of Martian rovers. The profile texture was selected on the basis of the results of an experiment carried out on a specially designed laboratory stand in the Vibroacoustics Laboratory of the Institute of Machine Design Fundamentals. The criterion adopted was the minimum energy consumption [17].

TPU filament was selected as the tire material. The material with a hardness of 93 Shore A scale is characterized by very good shock-absorbing properties and return to its original shape after stretching. Filament properties: diameter 1.75

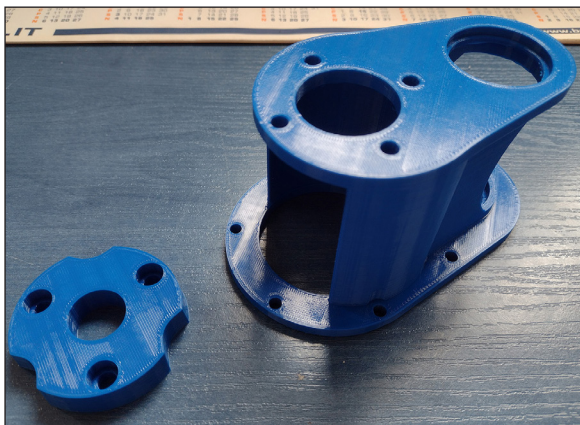

Fig. 3. Engine bracket



Fig. 4. Carbon fiber headband



Fig. 5. PLA rim, carbon strip rim and tire

mm, printing temperature from 200 °C to 230 °C, bed temperature from 50 °C to 70 °C, does not require a closed working chamber. A 200 gram tire was connected to a 400 gram rim with a flexible [7, 22] – silicone adhesive.

The most unfavorable positioning for the rim is the arrangement where the upper arm is vertical and the lower arms are at an angle of  $\pm 60^\circ$  from the vertical. The load is transferred symmetrically to the shaft by the steering knuckle, then the load is transferred further by the asymmetrical rim.

Such a complex way of loading a rim causes a complex state of stresses in the rim material. The rim is simultaneously compressed and bent in two sections. The most dangerous area is shown in Figure 6. In order to verify the correctness of the assumptions, it is necessary to perform the finite element analysis and verify the calculations by carrying out an experiment consisting in loading the rim as in the real system.

### NUMERICAL ANALYSIS

The analysis using the Ansys Workbench application allowed to determine the map of the Huber-Mises stress distribution for the 3D print rim model of PLA material (Fig. 7).

In order to simplify the analysis, a mirror image of the rim geometry was used. The value of the force corresponding to the destructive force resulting from the experiment of 1300 N was assumed as the load. The force was applied to the contact surface of the rim with the ground, which corresponds to the load occurring in the experiment. The mesh consisted of tetrahedral linear elements and was densified in places with the expected stress concentration. The force of 1300 N caused stresses of about 79 MPa and 72 MPa in

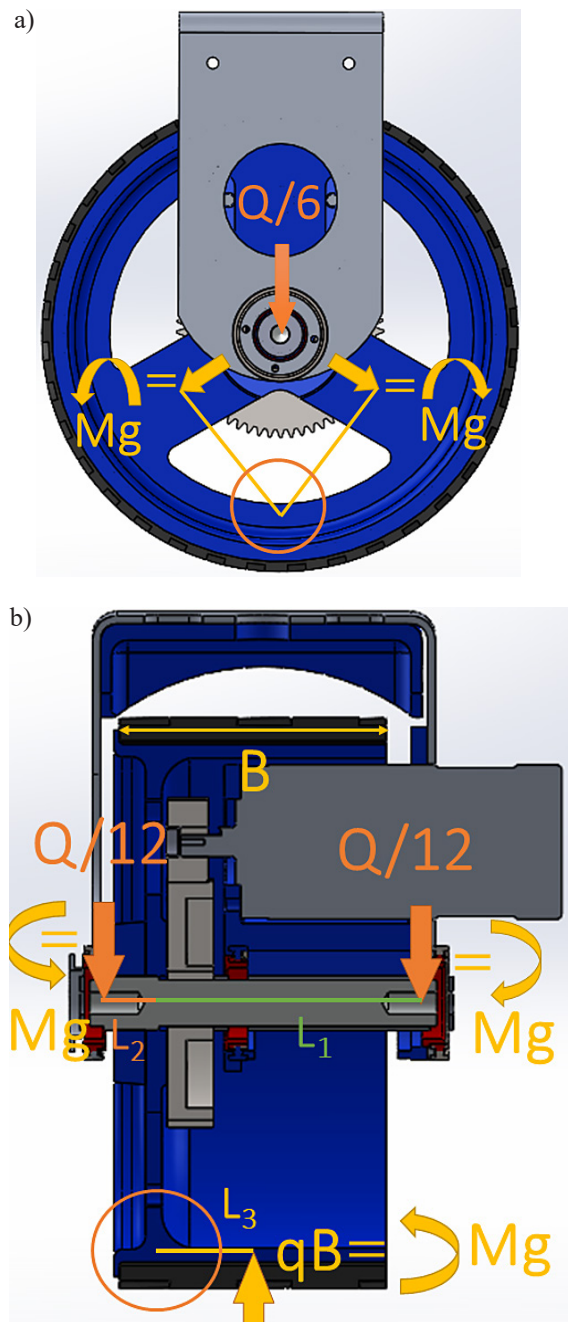

Fig. 6. Rim load

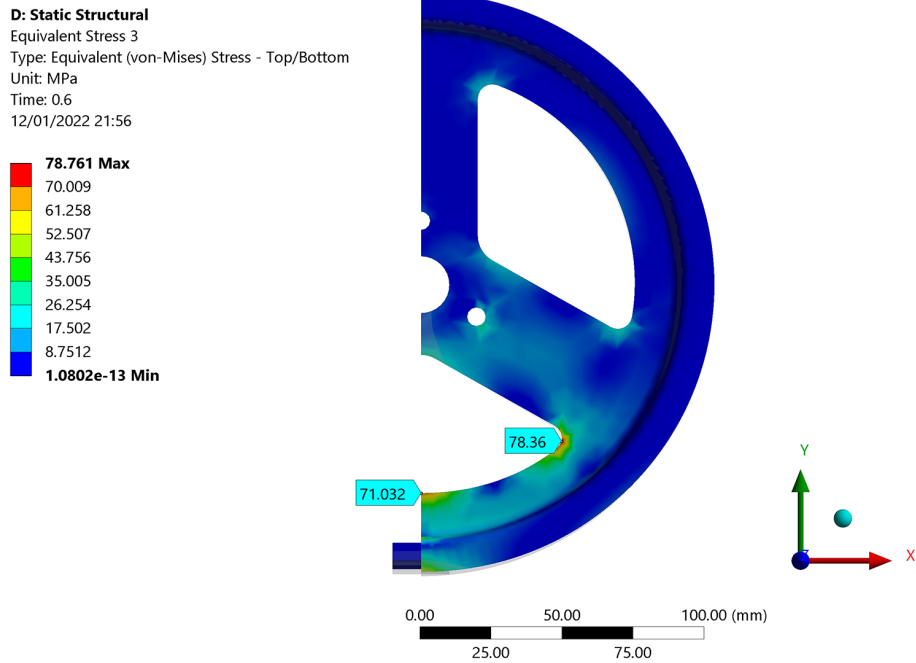

Fig. 7. Stress map of the analyzed wheel

Table 1. Mechanical properties of the adopted PLA material

Density	1.24 g/cm <sup>3</sup>
Tensile strength	50 MPa
Flexural strength	80 MPa

the places where the crack initiation and propagation occurred during the experiment.

The compressive strength of the PLA material used is about 80 MPa. The data from the experiment used in the numerical analysis confirm the strength data of the adopted material.



Fig. 8. Measurement station

## EXPERIMENT

In order to verify the calculations, an experiment was carried out on a specially prepared stand [18]. The rims were loaded by the screw mechanism on the measuring stand (Fig. 8). The wheel was pressed against the abutment surface by the axle, just like in a real vehicle. The measurement path consisted of a KMM20 strain gauge force sensor and a NI 9237 card. The signal was recorded with the LabVIEW SignalExpress program, and the graph was prepared with the Matlab R2018b program.

The conducted measurements showed that the PLA rim without the band first breaks in the indicated dangerous cross-section (Fig. 9). The next cracks



Fig. 9. PLA rim

appear on the radii of the rounding of the technical (assembly) hole. To improve the design, the value of the fillet radii should be increased to improve the stress distribution and the hazardous cross-sectional area should be increased. The rim was damaged with the load force of 1300 N. The result is satisfactory, as the load capacity of the rim is five times greater than that assumed for a rim weight of 200 grams.

The carbon fiber band significantly increases the stiffness of the 400 g rim with a slight increase in weight. The rim (Fig. 10) does not deform like the PLA rim. The crack does not occur in the intended dangerous cross-section, but in the radius of the rounding of the technical (assembly) opening and in the assembly openings [2] for the last stage gear. Destruction occurs by tearing out the supporting arms (Fig. 11) [23]. Another type of damage results from the method of deformation of the rim with a stiffening carbon fiber band. A rim without a band deforms, changing its cross-sectional shape

from oval to elliptical. Such a change of shape causes that with the increase of the loading force – the arm of the bending moments acting on the cross-section increases.

It was not possible to register the maximum destructive force due to the scaling of the strain gauge force sensor to the value of 2000 N. The authors did not expect such a high value of force. The result is considered very satisfactory. From the curve approximation, the force can be estimated at 2400 N.

The course of the value of the force loading the rim is stepped (Fig. 12), it is the result of using a ratchet wrench and a limited range of its rotation. The test stand is located in the Vibroacoustics Laboratory of the Institute of Machine Design Fundamentals at the Faculty of Automotive and Construction Machinery Engineering.

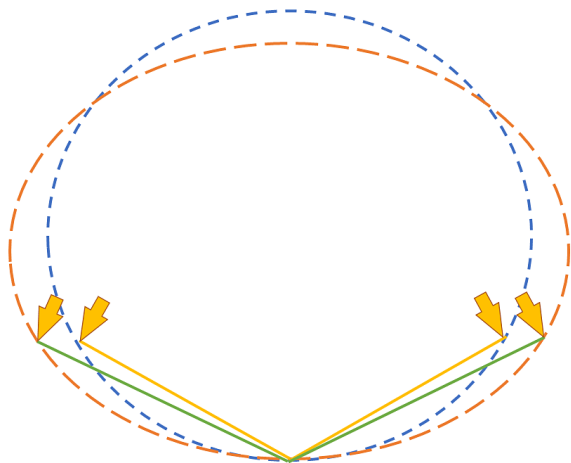

Fig. 10. Rim deformation

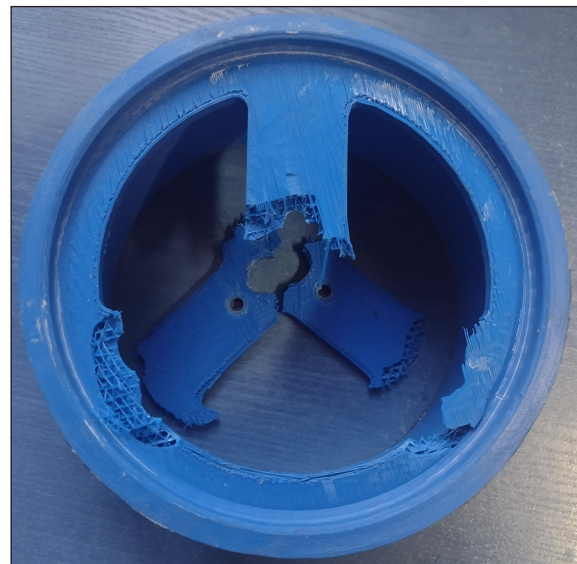

Fig. 11. PLA rim plus Carbon

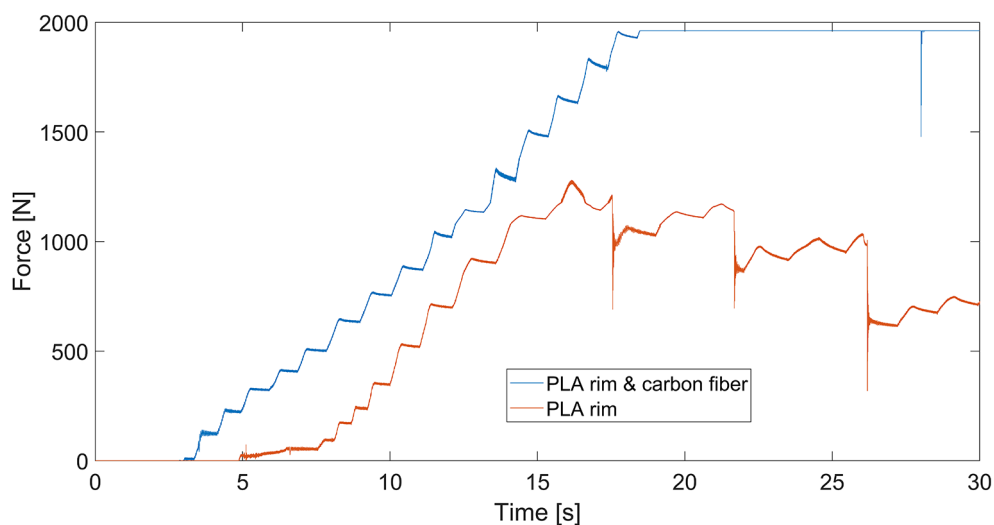

Fig. 12. The course of the values of loading forces [19]

## CONCLUSIONS

The conducted research confirms the correctness of the assumptions and indicates the advantages and certain limitations of the applied solution. It should be emphasized that the project is financed from the Scientific Club budget. The selected technology corresponds to the possibilities of its implementation by students, and the materials used are readily available. An innovative idea, easy to implement, gave better than expected results.

The solution presented in the study is part of a larger project. The project consists in the construction of a Mars rover by Bekker Team Scientific the Club from the Faculty of Automotive and Construction Machinery Engineering of the Warsaw University of Technology and the start of the European Rover Challenge.

The design study of a Mars rover wheel presented in the paper shows the possibilities of using polymeric materials used in 3D printing and the possibilities of combining the printout with other materials, e.g. carbon fiber. This combination gives designers new possibilities, with a very low weight we get relatively high durability.

To eliminate the effect of asymmetric load on the rim, a full circle with openwork filling and an internal multi-stage planetary gear or a more advanced wave gear should be used.

## REFERENCES

1. Batko W., Dąbrowski Z., Modern methods of vibroacoustic research (technical application), II, ITE – PIB, 2006.
2. Bielawski R., Rządkowski W., Kowalik M., Kłonica M., Safety of Aircraft Structures in the Context of Composite Element Connection, International Review of Aerospace Engineering (I.RE. AS.E) 2020; 13(5): 159–164. DOI: 10.15866/irease.v13i5.18805.
3. Boczkowska A., Krzesiński G. Composites and techniques of their production, Warsaw: Publishing House of the Warsaw University of Technology, 2016.
4. Buckley J.D., Edie D.D., Carbon – Carbon Materials and Composites, Noyes Publications 1993.
5. Dąbrowski H. Introduction to the mechanics of composite materials 1989.
6. Kapuściński J. Design and technology of composite materials, 1983.
7. Kłonica M., Bielawski R. Strength of Joints with “Hi-Lok” Fasteners in Aircraft Safety Considerations, Advances in Science and Technology Research Journal 2019; 13(4): 87–93. DOI: 10.12913/22998624/114179
8. Kurnik W., Tylikowski A. Mechanics of laminated elements, 1997.
9. Leda H. Polymer composites with continuous fibers, 2006.
10. Markuszewski D. Comparison of various types of damage symptoms in the task of diagnostic composite profiles, Diagnostyka 2019; 20(3): 105–110. DOI 10.29354/diag/111799
11. Sclater N., Chironis Nicholas P. Mechanisms and mechanical devices sourbook.
12. Skórski W., Zawisza M. 2019. Influence of the composite modification of the wooden wing skin of the glider on deflection lines and resonance vibrations. Polimery 2019; 64(4): 267–271.
13. Vasiliev V.V., Morozov E.V. Advanced Mechanics of Composite Materials, Elsevier, 2007.
14. Wilczyński A.P. Polymer fiber composites, WNT, 1996.
15. <https://roverchallenge.eu/en/publishing-the-erc-pro-rules-and-the-erc-student-rules-update/>
16. <https://spidersweb.pl/autoblog/perseverance-opportunity-spirit-lazik-marsjanski/>
17. Gorzým M. Stand for testing the rolling resistance of an off-road wheel of a special vehicle, SiMR, 2022.
18. Grzybek A. Concept of the stand for testing the strength parameters of polymer wheels, SiMR, 2022.
19. Markuszewski D., Wądołowski M., Bielak m., Grzybek A.: Polymer materials and carbon fiber in the construction of a Mars rover wheel, Diagnostics of Polymer Materials, 10th Scientific and Technical Conference, 2022.
20. Gryz K. Engineering thesis – A concept of a special vehicle’s manipulator, SiMR 2021.
21. Podembski K. Suspension – internal materials of KN Bekker Team.
22. Kłonica M., Bielawski R., Żokowski M. Comparative Tests of Shear Strength of Adhesive Lap Joints After Thermal Shocks, Advances in Science and Technology Research Journal 2021; 15(4): 364–375. DOI: 10.12913/22998624/143270
23. Grządziela A., Kluczyk M., Shock Absorbers Damping Characteristics by Lightweight Drop Hammer Test for Naval Machines. Materials 2021; 14: 772. DOI: 10.3390/ma14040772